

# Trimble R780

## GNSS Smart Antenna

### Rugged, reliable positioning

The ultra-rugged Trimble® R780 GNSS Smart Antenna offers unmatched reliability for construction site positioning. Ideal for use on small and large job sites, the R780 can serve as a GNSS rover system or as a base station for other GNSS operations including machine control.

The R780 is scalable from entry-level to high precision applications to fit your needs. It has a longer battery life and incorporates the latest technology to make construction surveying easier, safer and more productive.

### Rugged, all-in-one solution

- Compact design with unprecedented strength and durability, easy to use and virtually indestructible
- Tilt compensation makes site positioning easier and more accessible for new users, while saving time and money for experienced users
- The most rugged receiver Trimble has ever built helps you eliminate downtime
- Real-Time Kinematic (RTK) corrections for higher-accuracy site measurements
- More GNSS satellites increase productivity and uptime and give you greater accuracy in difficult conditions such as tree canopy or urban areas
- Use the eBubble to see the verticality of the receiver in Trimble FieldLink Software instead of on the rod bubble for more efficient surveying, especially in low light conditions

GNSS receiver, antenna, radio and battery in one unit—ultra-rugged housing built to withstand harsh construction site conditions.

CenterPoint® RTX delivers fast, high accuracy GNSS positions worldwide via satellite or cellular/IP without a local base station or VRS network.

VRS and IBSS compatible for a more economical solution.

Connected-site enabled with integrated Wi-Fi® Bluetooth® and wideband radio.

Rapid daily base station setup with a single button push using Trimble AutoBase™ technology.

Tilt compensation functionality to measure accurate points without leveling the pole.

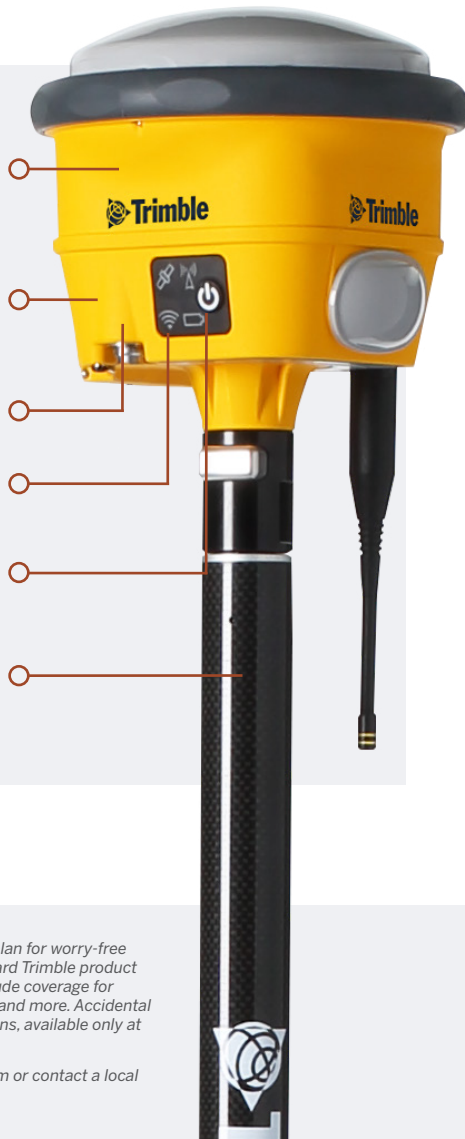

### Flexibility

The R780 is compact and can easily go from carrying case to range pole, tripod, t-bar or vehicle with a single click so you can get going faster.

### Trimble ProPoint technology

Trimble ProPoint™ GNSS technology uses all available signals to provide survey-grade positioning in challenging environments where other GNSS systems either can't provide a solution at all or produce unreliable error estimates.

### Trimble xFill technology

Trimble xFill® technology seamlessly fills in for gaps in RTK or VRS connection streams if the connection is lost, expanding site productivity by allowing short excursions into locations where GNSS corrections were not previously available.

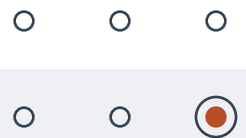

Add a Trimble Protected protection plan for worry-free ownership over and above the standard Trimble product warranty. Added enhancements include coverage for wear & tear, environmental damage, and more. Accidental damage is covered with Premium plans, available only at point-of-sale in selected regions.

For details, visit [trimbleprotected.com](http://trimbleprotected.com) or contact a local Trimble distributor.





# Trimble R780

## GNSS Smart Antenna



### Tilt compensation

Using the R780 and Trimble FieldLink Software it is now possible to capture accurate points while standing, walking or driving the site in a vehicle, while the receiver is not level.

Full GNSS tilt compensation makes FieldLink easier to learn for beginners and saves significant time for more experienced contractors.

- Easily and safely survey hard to reach areas (corners, traffic lanes, utility flowlines)
- Faster measurements
- More efficient stake-outs
- No magnetic interference

It has never been so easy to survey. Initial site work and topos can even be done base station-free using satellite-delivered GNSS corrections to the rover.

### Applications

With Trimble FieldLink Software, you can:

- Layout Mechanical Electrical and Plumbing points
- Locate and/or verify Concrete and Steel Placement
- Determine cut/fill on a range pole
- Check Elevations
- Record tilt data when taking measurements
- Stake or Record site features
- Measure progress and calculate material aggregate and concrete volumes
- Carry out as-built measurements, grade checks and thickness checks

Using your smartphone, quickly check the health and status of the receiver with the Trimble GNSS Status App. For a more in-depth look, the Trimble Web UI can be accessed over Wi-Fi. Setting a new standard for rugged reliability, the R780 keeps your crews working, not wasting time with GNSS maintenance.

### Reliable base station

The R780 can also serve as a powerful site base station, receiving corrections for the rover. It is the easiest base station on the market. The R780 will automatically establish a connection with the machine radio or GNSS rover and begin transmitting corrections—just put it on the tripod, switch it on and go.



#### Trimble Building Construction Field Solutions

10368 Westmoor Drive  
Westminster CO 80021 USA  
800-361-1249 (Toll Free)  
+1-937-245-5154 Phone  
fieldtech@construction.trimble.com